

# Sprint

Productivity and safety  
without compromises.

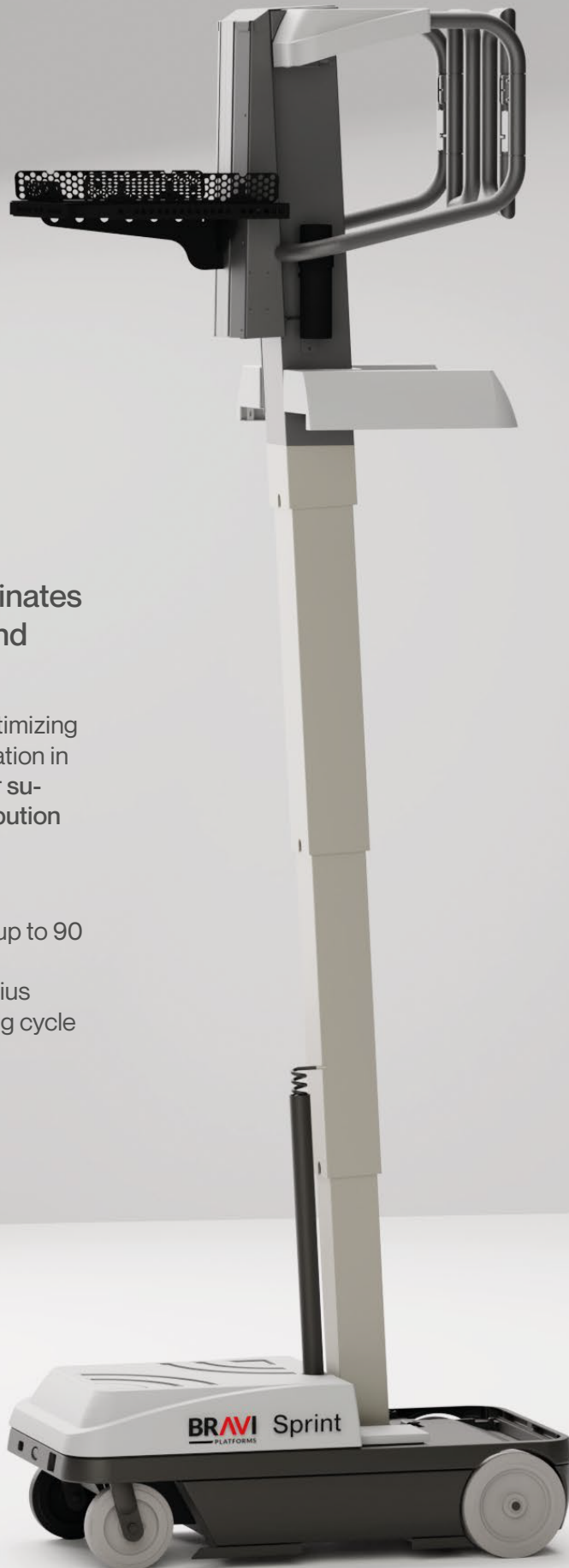

Sprint is the picking platform that eliminates the use of ladders, improving safety and efficiency.

It simultaneously lifts operators and materials, optimizing work time. The ultra compact design allows operation in tight spaces, reducing the risk of injuries. Ideal for supermarkets, retail stores, warehouses and distribution centers, ensuring a faster and safer workflow.

- Working height up to 5.35 mt (17.6 ft)
- Motorized adjustable load tray with capacity up to 90 kg (198 lbs)
- Maximum maneuverability with 0° turning radius
- Premium 245 Ah batteries for a longer working cycle between charges, up to two shifts

# Sprint

## Technical specifications

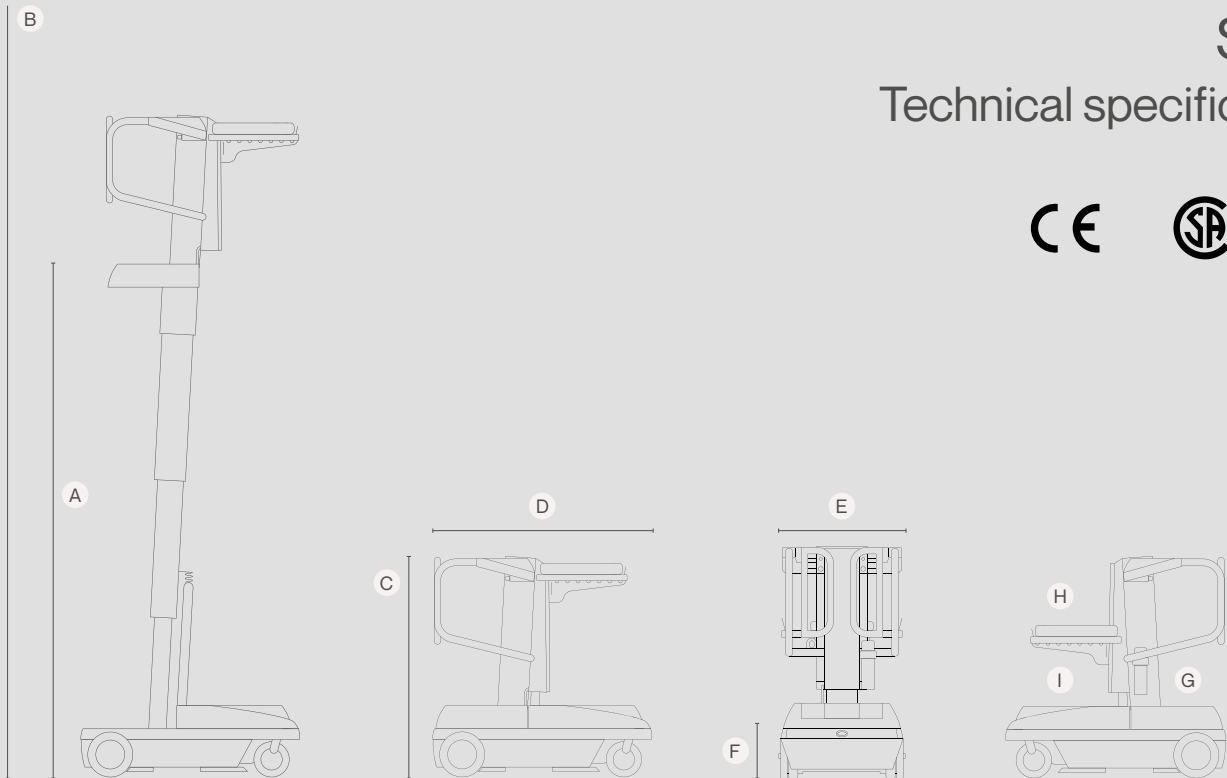

	METRIC	US
A Platform Height	3350 mm	10 ft 11 in
B Working Height	5350 mm	17 ft 6 in
C Height stowed	1440 mm	56.6 in
D Platform Length	1500 mm	59 in
E Platform Width	808 mm	31.8 in
F Entry Step	360 mm	14 in
G Platform Capacity	130 Kg	286 lbs
H Load Tray Capacity	90 Kg	198.4 lbs
I Load Deck Capacity	113 Kg	249 lbs
Unit Weight (CE)	690 Kg	1521 lbs
Rated number of occupants	1	1
Drive Speed (stowed)	5 Km/h	3.1 mph
Drive Speed (elevated)	1.2 Km/h	0.74 mph
Raise/lower speed	18/15 sec	18/15 sec
Inside turning radius	Zero	Zero
Outside turning radius	1600 mm	62 in
Gradeability (while elevated)	max. 2°	max. 2°
Power source	110/220 V ca 24 Vcc	110/220 V ca 24 Vcc
Batteries	n°4 - 6V 245Ah@20h	n°4 - 6V 245Ah@20h