

Pedestrian stacker truck 2.0 ton

BT staxio

W-series

SWE200D



Pedestrian stacker double stacking

Specification for stacker trucks					SWE200D
Identification	1.1	Manufacturer			BT
	1.2	Model			SWE200D
	1.3	Drive			Electric
	1.4	Operator type			Pedestrian
	1.5	Load capacity/rated load	Q	kg	1000
		Support arm capacity/fork and support arm capacity	Q	kg	2000/800+1200
	1.6	Load centre	c	mm	600
	1.8	Load distance, centre of support arm wheel to face of forks	x	mm	873
	1.9	Wheelbase	y	mm	1483
Weight	2.1	Service weight including battery		kg	879
	2.2	Axle load, with load, drive/castor/support arm wheel		kg	570/360/1155
	2.3	Axle load, without load, drive/castor/support arm wheel		kg	570/100/215
Wheels	3.1	Drive/castor/support arm wheel			Friction/Vulkollan/Vulkollan
	3.2	Wheel size, front		mm	Ø230x70
	3.3	Wheel size, rear		mm	Ø85x74
	3.4	Additional wheels (dimensions)		mm	Ø125x50
	3.5	Wheels, number front/rear (x=driven wheels)			1x+2/4
	3.6	Track width, front	b ₁₀	mm	550
	3.7	Track width, rear	b ₁₁	mm	390
Dimensions	4.2	Height, mast lowered	h ₁	mm	1535 *)
	4.3	Free lift	h ₂	mm	166 *)
	4.4	Lift	h ₃	mm	2010 *)
		Lift height	h ₂₃	mm	2100 *)
	4.5	Height, mast extended	h ₄	mm	2520 *)
	4.6	Initial lift	h ₅	mm	120
	4.8	Stand height (optional platform)	h ₇	mm	150
	4.9	Height of tiller in drive position, min./max.	h ₁₄	mm	865/1235
	4.15	Height, fork lowered	h ₁₃	mm	90
	4.19	Overall length	l ₁	mm	1910
	4.20	Length to face of forks	l ₂	mm	760
	4.21	Overall width	b ₁	mm	770
	4.22	Fork dimensions	s/e/l	mm	60/180/1150 *)
	4.24	Fork-carriage width	b ₃	mm	674
	4.25	Width over forks	b ₅	mm	570 *)
	4.31	Ground clearance, with load, below mast	m ₁	mm	22
	4.32	Ground clearance, centre of wheelbase	m ₂	mm	22
4.33	Aisle width for pallets 1000 x 1200 crossways	A _{st}	mm	2448	
4.34	Aisle width for pallets 800 x 1200 lengthways	A _{st}	mm	2355	
4.35	Turning radius	W _a	mm	1633	
Performance data	5.1	Travel speed, with/without load		km/h	6/6
	5.2	Lift speed, with/without load		m/s	0.14/0.27
	5.3	Lowering speed, with/without load		m/s	0.38/0.32
	5.8	Max. gradeability, with/without load		%	8/12 ¹⁾
	5.10	Service brake			Electromagnetic
Electric motor	6.1	Drive motor rating S2 60 min		kW	1.5
	6.2	Lift motor rating at S3 15%		kW	2.2 ²⁾
	6.4	Battery voltage/nominal capacity K _s		V/Ah	24/225 *)
	6.5	Battery weight		kg	219 *)
Others	8.1	Type of drive control			BT Powerdrive

¹⁾ Measured according to company standard

²⁾ S3 6%

*) Further alternatives are available and will produce other values.

Data is based on standard configurations: h₂₃ = 2100 mm Duplex Tele Panoramic View mast.

Truck performance and dimensions are nominal and subject to tolerances.

BT Products AB products and specifications are subject to change without notice

Battery dependent dimensions

BT staxio

Dimensions		Battery change		SWE200D		
				Lift out		Sideways
		Battery compartment		Medium	Large	Large
1.9	Wheelbase	y	mm	1483	1533	1533
4.19	Overall length	l ₁	mm	1910	1960	1960
	without platform		mm	1995/2385	2045/2435	2045/2435
4.20	Length to face of forks	l ₂	mm	760	810	810
	without platform		mm	853/1243	853/1243	853/1243
4.33	Aisle width for pallets 1000x1200 crossways	A _{st}	mm	2448	2498	2498
	without platform		mm	2533/2933	2583/2983	2586/2983
4.34	Aisle width for pallets 800x1200 lengthways	A _{st}	mm	2355	2405	2405
	without platform		mm	2440/2840	2490/2890	2490/2890
4.35	Turning radius	W _a	mm	1633	1683	1683
	without platform		mm	1718/2118	1768/2168	1768/2168
6.4	Battery voltage, nominal capacity K ₅		V/Ah	24/225	24/300	24/260
6.5	Battery weight, min.—max.		kg	189—250	230—280	209—250

Mast dimensions

SWE200D			Duplex Tele			Dupl. Tele Panoram. View		
h ₂₃	Lift height (h ₁₃ +h ₃)	mm	1700	1900	2100	1700	1900	2100
h ₃	Lift	mm	1610	1810	2010	1610	1810	2010
h ₁	Height, mast lowered	mm	1340	1440	1540	1335	1435	1535
h ₂	Free lift, ground to top of forks	mm	166	166	166	166	166	166
h ₄	Height, mast extended	mm	2125	2325	2525	2120	2320	2520

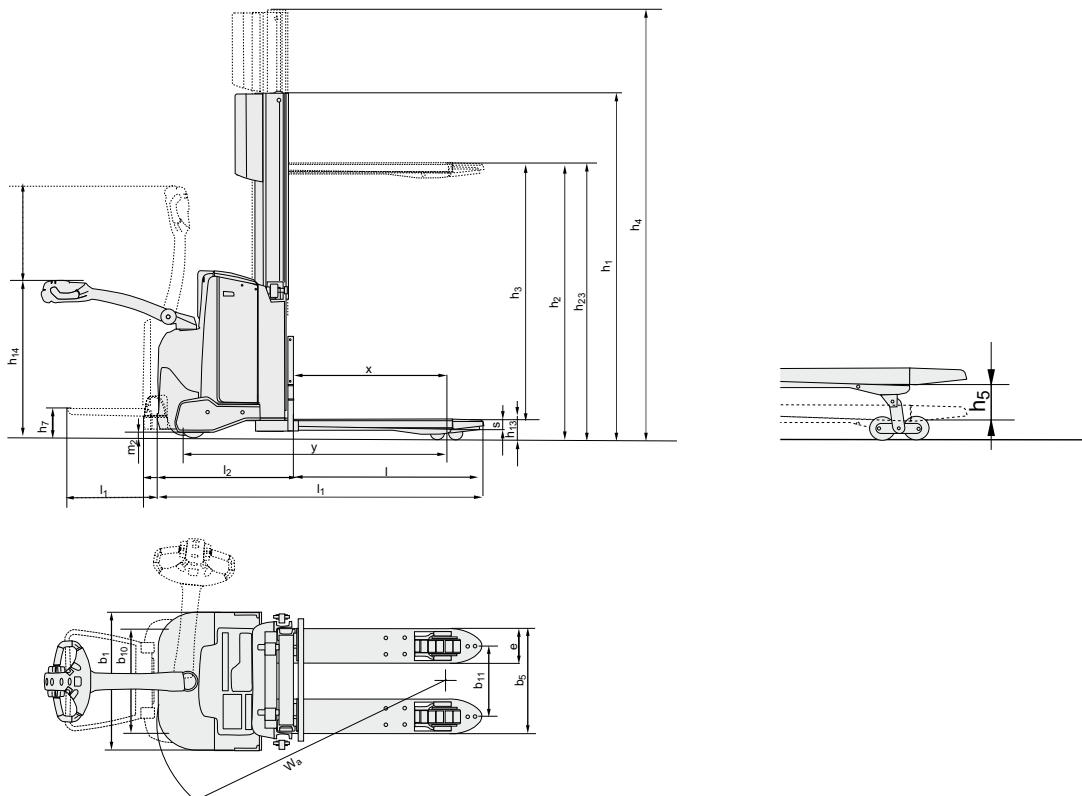

Truck features:

- BT Powerdrive System
- Fingertip controls
- Electronic braking system
- Electronic speed control
- Operator safety
- Storage compartments
- Automatic switch-off
- Click-2-creep
- Programmable performance
- Easy access for maintenance
- Built in charger (option)
- Sensilift (option)
- Flip-up operator platform (option)
- Toyota I_site: truck fleet management system (option)
- Hydraulic oil for low temperatures (option)

